

Technical Report for ACFR[®] Conductor

Keywords – Stranded Carbon Fibre composite Cable, Flexibility, Ohmic loss, Easy Installation

Abstract:

Globally ACSR and AAAC conductors are commonly used as overhead conductor for energy delivery application. High density transmission corridors are the need of energy utilities to optimise the right of way. So the use of High Temperature Low Sag (HTLS) conductors has been increased to address the increasing congestions in the existing transmission network. The selection of suitable HTLS technology considering the requirement with respect to increase in power transfer capacity, existing ground clearance, existing tower loading and cost of capital investment is not only the deciding factor but also the operational efficiency (Ohmic losses) over a period of its lift time and installation of those conductors in the existing terrain are the major parameters needs to be considered for the right technology adoption. We directed our attention to this operation efficiency and

easy installation and developed and tested Aluminium Conductor Fiber Reinforced (ACFR[®]) conductor and it's Carbon Fiber Composite Cable (CFCC[®]) as the core.

General:

ACFR[®] is one of HTLS conductor and its construction shown in Fig 1 is as simple as ACSR conductor where the stranded steel core is replaced with stranded carbon fiber core. The outer conductive layer is either EC grade hard drawn aluminium wire used in ACSR conductor or thermal resistance wire of Al-Zr alloy or EC grade thermal resistance annealed aluminium wire. And trapezoidal wire shaped is selected to increase conductive area which leads to better ohmic losses. The selection of the outer conductive layer's material and shape depends on application and the preference of the energy utilities.

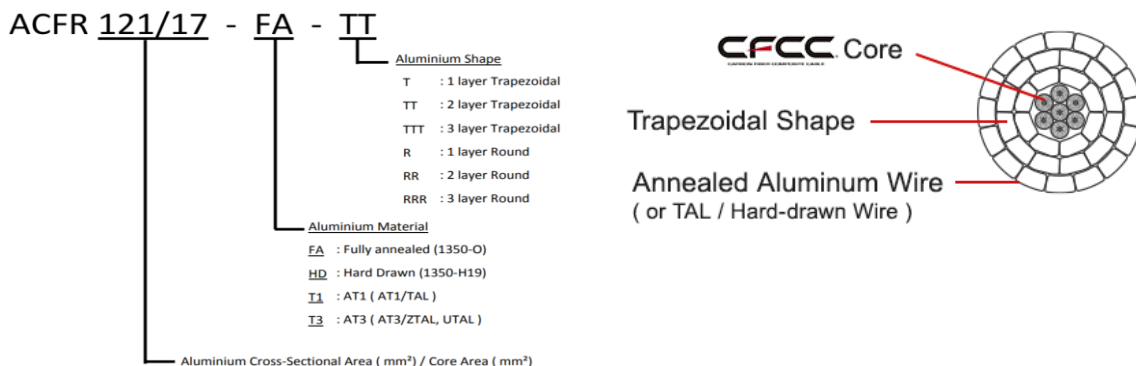

Fig 1: ACFR[®] Conductor's product description and its construction

CFCC® Core:

Now a day, the carbon fiber composite core conductor technology has been preferred by the utilities among HTLS conductor technology because of high strength to weight ratio, lower thermal expansion and almost zero creep. The popular composite core technology are mostly a single core or several number of single wires bunched together. But the challenge of this popular carbon fiber composite core technology is flexibility which leads to handling and installation work. We developed a technology to strand carbon fiber composite

materials called CFCC® core to make it flexible and easy to handle during installation. This innovated technology is coming from accumulated know-how about stranding material like steel and fiber in other business field which is Tokyo rope's core competence. CFCC® core consists mainly of carbon fibers (filaments) and matrix resins. Table 1 compares the characteristics of CFCC® core and steel stranded wire. CFCC® has 1/5 the weight, 1/12 the thermal expansion coefficient compared with the same size steel wire.

Item		Characteristic	
		CFCC	Steel
Material		CFCC	Steel
Strands		7/2.6	7/2.6
Calculated Cross Section	mm ²	37.20	37.16
Outer Diameter	mm ²	7.8	7.8
Weight	kg/km	60.0	291.3
Tensile Load	kN	79.5	44.0
Elastic Modulus	N/mm ²	126,000	206,000
Thermal Expansion	10 ⁻⁶ /°C	1.0	11.5

Table 1: CFCC® & Steel core characteristics comparison

ACFR® Characteristics

ACFR®'s maximum operation temperature is 180°C (Emergency 200°C). This temperature limitations do not come from the aluminium wires but from the CFCC® core, as temperatures approaching the limit or higher can accelerate aging if sustained for long periods of time. CFCC® core is designed for 180°C at maximum operation temperature

The comparison of conductor characteristics of ACSR 428 mm² (Zebra type) & ACFR 520 mm² is shown in Table 2. The aluminium cross section area of ACFR® is higher than ACSR, making the current carrying capacity 2 times more than ACSR by maintain same sag. DC resistance of ACFR® conductor is less than 20 % of the ACSR Conductor.

Description	Unit	ACSR 428	ACFR 520
	AL Type	-	1350-H19
AL Shape	-	Round	Trapezoidal
Diameter	mm	28.62	28.14
Weight	kg/km	1621	1540
Area	mm ²	484	570
DC resistance	ohm/km	0.06868	0.0536
UTS	kN	129	147
MCOT	°C	85	180
Ampacity	A	562	1617
MOE Below KPT	kg/mm ²	7190	6407
MOE Above KPT	kg/mm ²	19380	13770
CTE Below KPT	10 ⁻⁶ /°C	19.44	18.38
CTE Above KPT	10 ⁻⁶ /°C	11.5	1

Table 2: ACSR & ACFR® Characteristics (Zebra)

ACSR & ACFR® Sag and Temperature Characteristics:

Next is a comparison of the sag and temperature characteristics shown in Fig. 2, when stringing with a span length of 350 m? The sag at 80°C, which is the continuous allowable temperature of normal type conductor ACSR, is 6.7 m for ACFR® against 9.43 m for ACSR. ACFR® can suppress sag by about 2 m. Moreover, in the case of maximum operating temperature at 180°C, the sag for ACFR® is about only 7.2 meters that which still maintains the ground clearance.

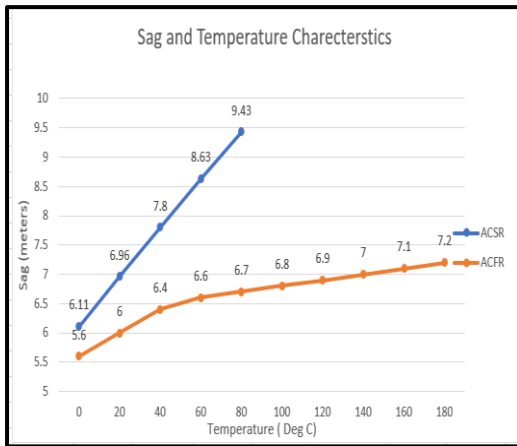

Fig 2: ACSR and ACFR® Sag & Temperature

Sag Tension Design

When the temperature of the conductor increased, the aluminium wires usually expand than higher rate than the core. This expansion is accompanied by a proportional reduction in its share of the total tensile load on the conductor. At a given temperature (called the "knee-point" shown in Fig 3), the aluminium becomes mechanically "unloaded", the ACFR® conductor being supported only by its core. It is at this point that the sag is governed only by the thermal expansion of the core. Knee point temperature is around 50 to 80°C in case of annealed wire type.

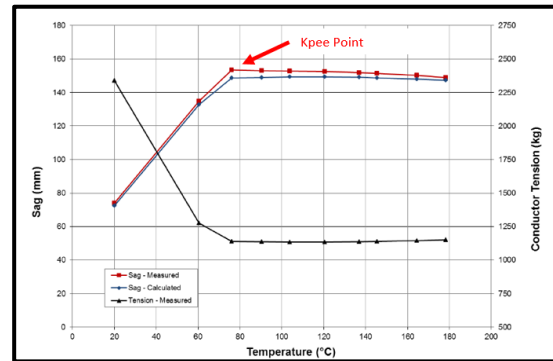

Fig 3: ACFR®'s knee point

Various Performance Test Results

We conducted various performance tests for conductor and core shown in table 3 in respect to Design, Installation, and Service / operation aspect using outside accredited laboratory and the results were all satisfactory.

Design	Installation	Service/Operation
Tensile Strength	Sheave	Sag / Tension
Stress Strain	Bending	Salt Spray
Electric Resistance	Torsion	Heat Exposure
Creep	Radial Crush	Heat Stress
Thermal Expansion		Temperature Cycle
Tg		Strand Brittle Fracture
Flexural Strength		UV aging
Elongation		

Table 3: List of ACFR®'s implemented Tests

Some of the testing result are described here.

Heat Exposure (for CFCC® core):

Maximum operation temperature for ACFR® is 180°C. This temperature limit is determined by the thermal endurance capability of the CFCC® core. In order to check its capability, CFCC® core was exposed to 180°C and each three (3) samples at 400-hour, 1500-hour, 2500-hour, 5000-hour, 52 weeks were measured their remaining tensile strength. Its result from each set were ten plotted on a log-log Chart and its residual strength was extrapolated out to forty (40) years. Calculated strength after 40 years was 106.1% RTS shown in Fig 4.

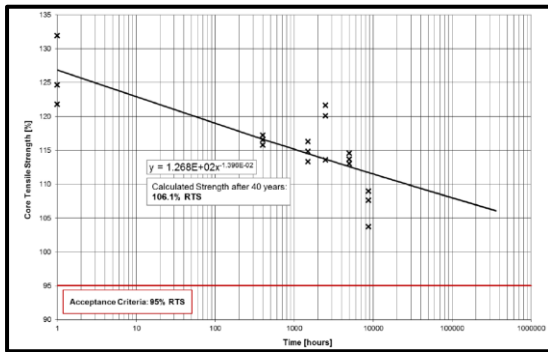

Fig 4: Heat exposure Test at Kinectrics

Heat Stress (for CFCC® core):

Emergency operating temperature for ACFR® is 200 °C. This temperature limit also determined by the thermal endurance capability of the CFCC® core. CFCC® core was exposed to 200 °C and tensioned at 25% RTS for 1000 hours shown in Pic 1. Its test result was more than 95% RTS.



Pic 1: Core installed for heat stress at Kinectrics

Corrosion Resistance (for ACFR® conductor):

Corrosion of the inner layer aluminium wires contacting the composite cable pose a problem. We examined the corrosion resistance of ACFR® based on CIGRE TB 426 which recommend to do salt spray test. Test was performed according to ASTM B117 for 1,000 hours. Result was that there were no significant degradation about tensile strength of aluminium and core, Tg, and flexural strength shown in Fig5 and 6.

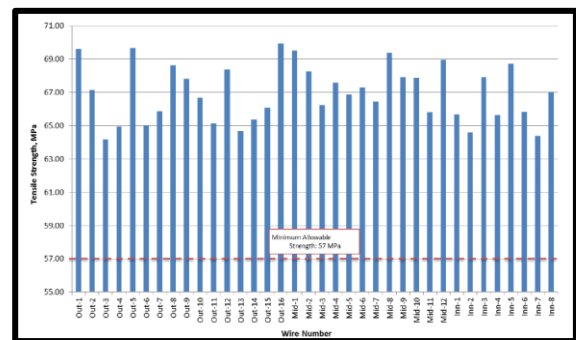

Fig 5: Measured tensile strength of Aluminium

Table 2-1: Tensile Strength Test Results after Salt-Spray Exposure

Conductor Component	Aluminum Wires (Outer Layer)	Aluminum Wires (Middle Layer)	Aluminum Wires (Inner Layer)	7/3.2, 9.6 mm CFCC Core
Average Tensile Strength	66.82 MPa	67.67 MPa	66.22 MPa	144.96 kN (119.8% RTS)

Table 2-2: Flexural Strength and T_g Measurements before and after Salt-Spray Exposure

	Parameter			
	Flex Storage Modulus	Flex Loss Modulus	TAN Delta	Horizontal Shear Strength
Before Salt Spray Exposure (A)	200.13 °C	229.11 °C	237.02 °C	37.4 MPa
After Salt Spray Exposure (B)	198.29 °C	233.24 °C	238.79 °C	36.9 MPa
Percent Degradation (A-B)/A	1.92%	-1.80%	-0.75%	1.34%

Fig 6: Result of Salt Spray Test at Kinectrics

Fittings & Accessories

ACFR® conductor is installed using conventional tools and equipment. While the installation of ACSR® Dead ends and splices is slightly different from the conventional conductor's fittings, but the conductors are installed with similar way.

Tension Joint

Design of dead end clamp for ACSR® is similar with that of ACSR except for using aluminium buffer in order to reduce the suppressing and crushing force to CFCC® core. The sleeve was slightly longer at full length than the sleeve for ACSR, which leads to fully secured endurance at high temperature as well as grip strength. An example of the compression type dead-end clamp and mid span joint for ACSR® is shown in Pic 2 and 3.

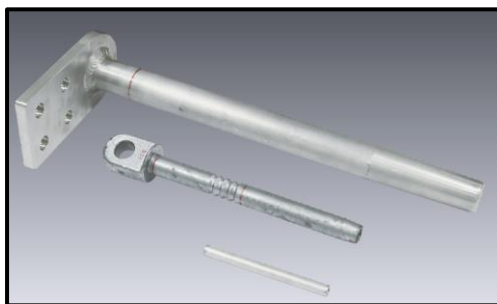

Pic: 2 Dead end clamp of ACSR®

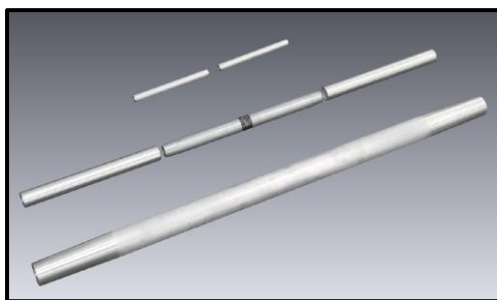

Pic 3: Mid Span of ACSR®

Installation

The ACSR® conductor's stringing method is quite similar with conventional ACSR's one thanks to its flexibility. This is the one of the biggest advantage of ACSR® which use stranded CFCC® core. Difference are only two point which are needs of extra caution about twisting and over-bending of

conductor which may lead to conductor's snapping. We usually dispatch our stringing advisor for lecture and monitoring in addition to providing stringing guideline as shown in Fig 7.



Fig 7 : Installation Guide Line

History and Operation Record

The research and development to strand the carbon fiber composite material to make it more flexible started in the year 1980's. The CFCC® core was first tested for civil construction application mainly focusing to replace the steel reinforcement with CFCC® to enhance corrosion resistance. The first deployment of CFCC® core for civil construction application was PC bridge project in Japan in the year 1986. In the year 2002 the CFCC® core was used instead of steel core in the overhead conductor application, the new conductor with carbon fiber composite core named ACSR® was introduced, tested and deployed in one of the transmission line project in Japan shown in Pic 4. This is the world first overhead transmission line using carbon fiber composite core and had energized in satisfactory operation until 2019. After checking product validity which took more than 10 years, we have started to promote our technology all over the world since 2012. Now ACSR® are used in Japan, China, Indonesia, India, Brazil and USA etc.



Pic 4: 66KV ACSR® line in Japan

Case Study

1) Amps upgrade by re-conducting

Here is the 132KV re-conducting ampacity upgrade project case study among well-known HTLS conductors shown in table 4. Utility expect 1000 amps from the current 379amps (more than 2.5 times) keeping ground clearance. ACSR® conductors shown in table 4. Utility expect 1000 Amps from current 379 Amps (more than 2.5 times) keeping ground clearance. ACSR® conductor can achieve the required 1000 Amps with the best ohmic losses keeping the same sag as existing ACSR.

Description	ACSR	ACFR	ACCC	ACCR	INVAR	GAP
OD	21	21	20.50	20.04	19.60	20.6
Weight	974	827	834	801	818	955
Ampacity at 75°C	379	440	434	411	355	403
Tension 32 °C full wind	2840	2750	2840	2839	2457	2758
Sag at 75°C - 365 m span	8.83	8.13	7.63	8.46	8.59	7.93
Sag @1000 Amps	-	8.24	7.81	9.74	-	9.8
Temperature @ 1000 A	-	162.5	166.8	182.6	-	187.1
AC resistance of 379 A	0.171	0.121	0.124	0.138	0.186	0.145
AC resistance of 1000 A	-	0.158	0.163	0.188	-	0.199
Ampacity at 8.83m	379	1061	1049	650	420	780
Temperature at 8.83m	75	180	180	104	82.35	130

Table 4: Case study for 132kV

2) Long spans for new line

HTLS conductors have been utilized for not only upgrading existing lines but also for allowing longer spans for newly constructed lines while maintaining required clearance and capacity. TACFR (Thermo-resistant Aluminum-alloy Conductor Fiber-Reinforced) in the table5 was used for the new construction of 132kV line (3 phase x 1 circuit) in steep mountainous terrain in Brazil. TACFR was used for relatively longer spans in the mountainous terrain which contains over 1000m long spans due to the cancellation of some towers (ROW problems) while conventional ACSR Linnet was installed for moderate spans in the flat terrain. In this area, sharp mountain faces and hilly terrain result in a limited number of 'feasible' tension/pull sites so that conductor was installed by Lay out method. Reduction in the number of towers can lead to reduction of initial construction cost.

Comparison ACSR/ACFR	ACSR Linnet	ACFR Linnet
● Aluminum/Shape	HA/Round	TA/Trapezoidal
● Cross Sectional Area of Al(mcm)	170.5	215.0(+26%)
● Overall Diameter (mm)	18.31	18.50(+0.19)
● Weight (kg/km)	689.9	636.0 (-7.8%)
● Rated Tensile Strength (kN)	63.0	71.0 (+12%)
● Max Operating Temp (°C)	70	150

Table 5: Comparison ACSR vs TACFR



Pic 5: 1087m long span (300m elevation difference)

Conclusion

ACFR® conductor which use stranded CFCC® core has outstanding advantages including lesser AC resistance and easy installation. ACSR® conductor technology will contribute to energy industry in your country.

Contact Information

Questions regarding this report may be submitted to the Tokyo Rope International contacts listed below. Questions will be answered by e-mail in a timely manner.

Ryuta (Luke) Ogoshi
International Marketing
ogoshi.ryuta@tokyorope.jp

Masaki Takayama
International Marketing
takayama.masaki@tokyorope.jp